

Poly-Classic Limited Lifetime Warranty

TURNCRAFT warrants that POLY-CLASSIC® COLUMNS will be free of manufacturing defects in material and workmanship for as long as the original purchaser owns the structure to which they were initially installed according to TURNCRAFT installation guidelines.* Should replacement be necessary under this limited warranty, the sole remedy shall be limited to the furnishing of new shafts, caps and/or bases to replace the defective part(s). Field-assembled joints are not warranted. Seller does not include and will not pay for, installation and painting as part of this limited warranty, nor shall Seller be liable for compensatory, consequential, or incidental damages under this limited warranty. There are no other express warranties contained herein, and all representations or affirmations made, and all samples and models shown are for illustrative purposes only.

**See reverse for a summary of trimming, assembly, and installation instructions.*

© 2004 Turncraft - TCT-054

Seller makes no warranty of merchantability or that the products covered hereby are fit for any particular purpose. There are no warranties, implied or expressed, except that contained on the face of this document.

SITE INSPECTION

I, the undersigned, have inspected the job site named below and found the TURNCRAFT Columns to be properly prepared, installed, and painted. (Warranty is valid only if blanks below are properly filled in.) Please print.

Name _____

Address _____

City/State/Zip _____

Site Address _____

City/State/Zip _____

Signature _____

Representing
TURNCRAFT _____

Warranty No. _____

Date _____

Mail a copy to:



P.O. Box 2429, White City, OR 97503
(541) 826-2911 • Fax: (541) 826-1393

Summary of Trimming, Assembly, and Installation Instructions

1. Measure the exact floor to ceiling height using a plumb to insure accuracy.
2. Cut the bottom of the column shaft as needed to achieve the measurement taken in step 1. Use an abrasive blade. **CAUTION:** Because the only the shaft is load bearing, its top and bottom edges must be level to achieve full, even contact between load surfaces and shaft. Use a rasp to level as required. **NOTE:** All height adjustments must be made from the bottom of the shaft. The top of the shaft must be trimmed only enough to achieve level contact with load surfaces, or to achieve correct installation of decorative capitals.
3. Slip one-piece cap and base on to column shaft (see figure 1). The two-piece cap and base are attached after the shaft is installed. If installation requires some method of securing the column in place before load is applied, use Poly-Classic Installation Kit #71760 (see figure 2) **NOTE:** Always drill clearance holes in columns and secure with through-bolts—**DO NOT USE SCREWS**—and do not over-tighten.
4. Apply standard construction adhesive to top surface of cap and bottom surface of base; then tip loosely assembled column shaft into position and lower load onto shaft to hold it in position. Align square part of cap with load surface above and push up against it to secure. Align square part of base with load surface below cap and push down until it is secure.
5. Caulk gaps between shaft and cap and base as desired.
6. Prepare by sanding all parts with 80 to 100 grits and paper. Sand to remove all glossy areas.
 - A. To paint with oil base paint, remove all dust and dirt by thoroughly wiping column with mineral spirits. Allow to dry completely. Use a high quality oil base paint. Primer is not needed if the **oil base paint** is the desired color.
 - B. To paint with **acrylic latex paint**, we commend using a high quality primer like *Sherwin-Williams® Prep Rite® Anchor-Bond* and a top coat like *Sherwin-Williams® Super Paint®*. Remove all dust and dirt before painting by thoroughly cleaning with a cleaner like *Simple Green®* or isopropyl alcohol. Allow to dry completely before priming.
7. Columns may be split to cover post, etc. using an abrasive Carborundum or carbide blade. To rejoin halves, we recommend using our Split Kit #72665 (spacers, straps, automotive body filler.) Instructions are included with the kit. **NOTE:** Split columns are not load bearing.

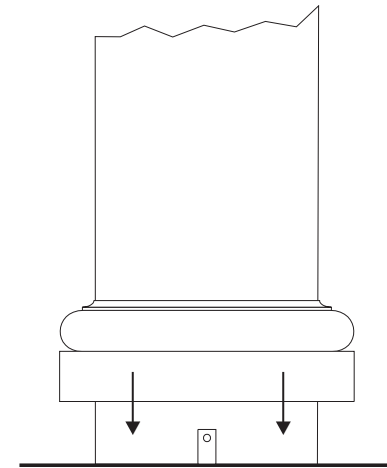

Fig. 1

Poly-Classic Installation Kit #71760

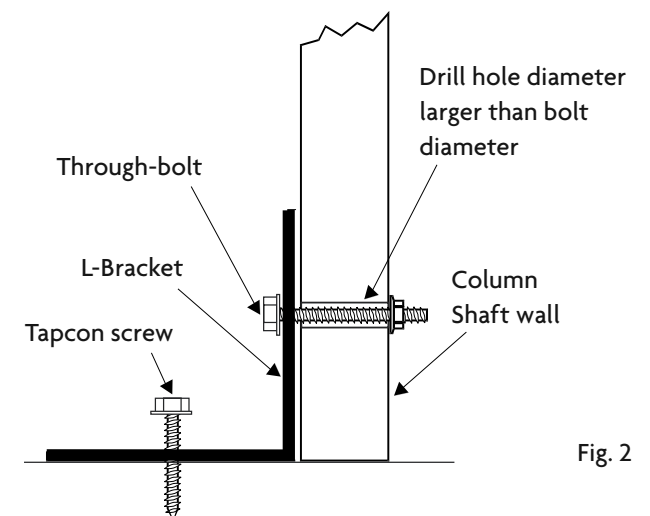

Fig. 2